

Don't leave a hole in the ceiling

A home's attic access, such as an attic hatch, pull-down stairs, or knee-wall door, often goes uninsulated and unsealed, creating one of the biggest holes in the thermal and air barrier between the attic and conditioned space.

A ¼-inch gap around the perimeter of a standard pull-down staircase can potentially leak the same amount of air that is supplied by a typical bedroom heating duct (~100 CFM). Unsealed, the attic access in a home leaks energy dollars and causes the house to be less comfortable. During winter, conditioned room air may escape to the ventilated attic, while in the summer, hot attic air (which may contain airborne insulation fibers) can infiltrate into the home.

Attic stairs

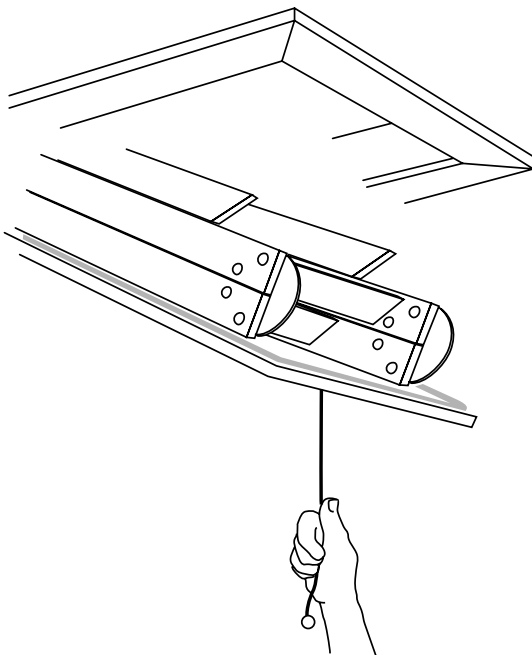

An attic access is often a big hole in the thermal envelope of the house. Adding an insulated cover and weatherstripping to a pull-down stairs can reduce infiltration and heat loss through this passageway. Latch bolts (not shown) may be installed to help ensure a tighter seal.

Attic hatch

One inexpensive and common type of access is referred to as a *scuttle hole* or *attic hatch*, which is simply a removable portion of the ceiling that allows access to the attic above. An attic hatch is commonly located in a closet or main hallway.

The installer should save the ceiling drywall piece that is cut out for the rectangular hole to be used for the hatch. To ensure a tight fit, care should be taken while installing the trim to make sure that it is flat and level. An uneven base may lead to greater air leakage. Weather-stripping can be installed either on the hatch itself or on the inside of the trim or base (where the hatch rests).

Scuttle hole cover

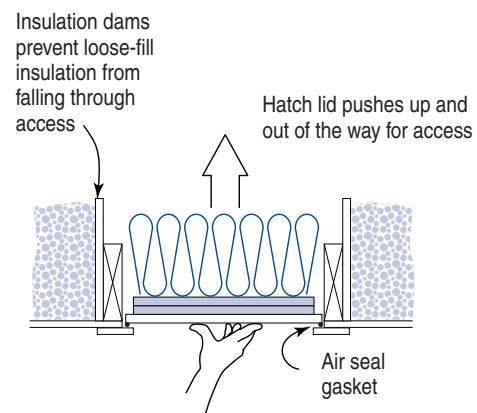

After the trim or base is aligned to seal properly, insulation should be added to the attic side of the hatch. Rigid insulated sheathing, such as extruded polystyrene (R-5 per inch), is recommended. Cut the insulated sheathing ¼ inch less than the hatch size to allow for clearance when moving the access panel. Apply 2 or more inches of insulation with construction adhesive and screws. As an added measure, glue the kraft-paper side of fiberglass batt insulation to the top of the last layer of rigid insulation. Try to achieve the same total R-value as the rest of the ceiling (~R-30).

Pull-down attic staircase

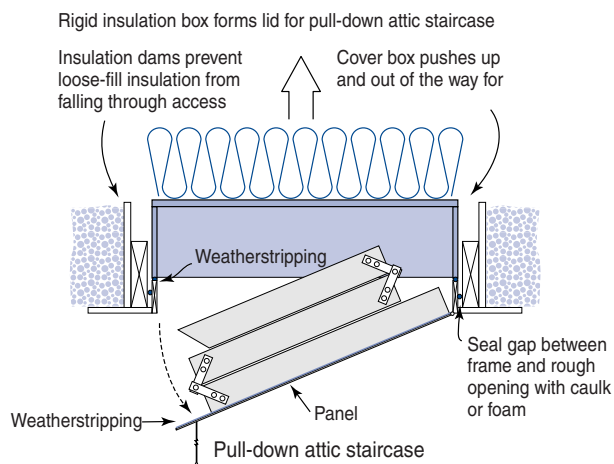

Attic stairs

Pull-down attic stairs are another common type of access. If possible, locate the pull-down stairs in an unconditioned part of the house (e.g., garage or covered patio or porch) that is also secure against potential break-ins. Other choices for locating the stairs include a main hallway or a bedroom such that opening the stairs will not interfere with the placement of furniture (a suggestion is immediately beyond the doorway).

The frame for the stairs fits in a rough opening and leaves a gap much like that for a door or window, which must be sealed. If the gap is small (less than $\frac{1}{2}$ inch), caulk can be used as the sealant. If a larger opening exists, then non-expanding foam or a backing material (backer rod) in conjunction with caulk is recommended. Expanding foam can be used but care must be taken due to its highly expansive nature; it could warp the frame and interfere with the ability of the stairs to open or close properly. To ensure a tight fit between the stairs panel and frame, weatherstripping or gasketing material should be added either to the frame or panel.

Insulated attic stairs cover box

Pay careful attention to inside and outside dimensions plus the height requirements for the specific measurements of the attic staircase being installed. The cover box should rest squarely on top of the attic stairs frame.

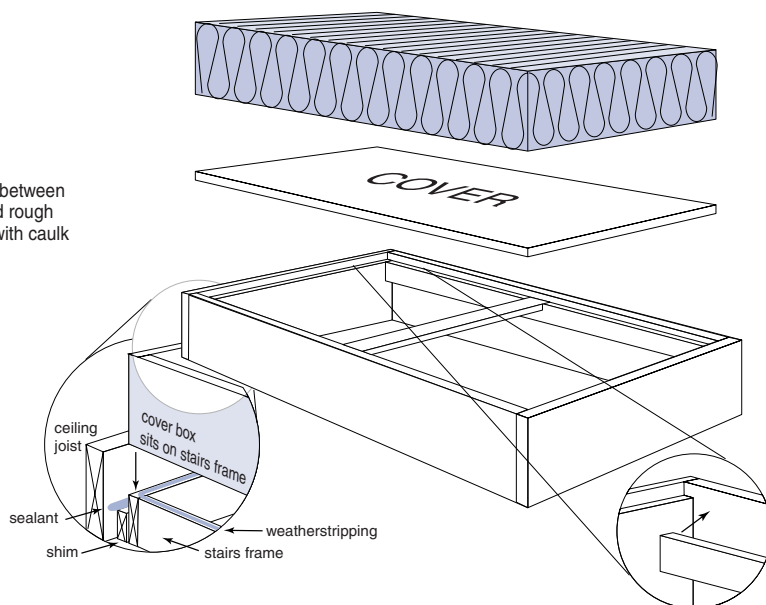

As with all home projects, follow manufacturer's instructions for proper installation of the attic stairs. These instructions often provide unique techniques and safety considerations for each particular unit. For safety and extended life of the stairs, be sure to cut them to the proper length. This action will avoid straining the hinges and reduce wear on the pivotal joints of the stairs.

Attic stairs cover box

To insulate attic stairs, a lightweight, moveable box can be fabricated from rigid foam or fibrous ductboard to fit over the stairs from the attic side. Insulating kits are also available through weatherization suppliers or from local hardware stores.

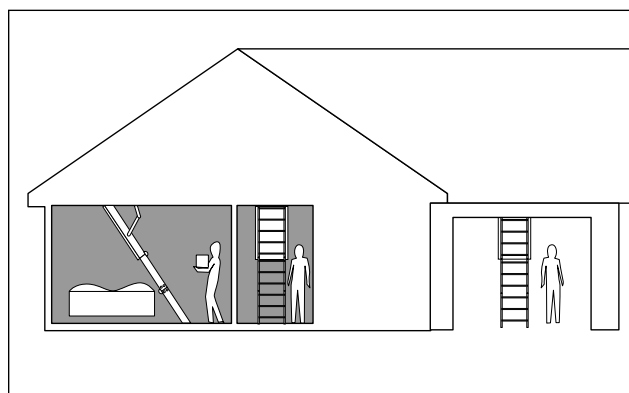

Attic access location

Location of a pull-down attic staircase is important. Consider the ease of access from the living space. The position of the staircase in relation to ceiling joists might also affect location—placing the staircase between joists instead of across joists can speed installation because structural cross-member framing is not as complicated. A garage location, where the vented attic is uninsulated, can eliminate the need for sealing and insulation.

Attic Decking

Attic decking is often used to provide additional storage space or as a platform for an HVAC unit installed in the attic. The decking is often installed directly on top of the ceiling joists; this limits the amount of space available for insulation and lowers the attic's average R-value. Sometimes boards used to move around the attic space are placed directly on top of the insulation, in contact with the ceiling joists; these should not be left to permanently compress the insulation.

To ensure proper insulation depth (a given R-value requires a minimum depth), the attic decking should be raised above the ceiling joists. This can be accomplished by "edge-nailing" 2x4s or 2x6s to the top of the ceiling joists where the decking is to be located. Install the decking securely to the top of the raised lumber after the insulation has been installed.

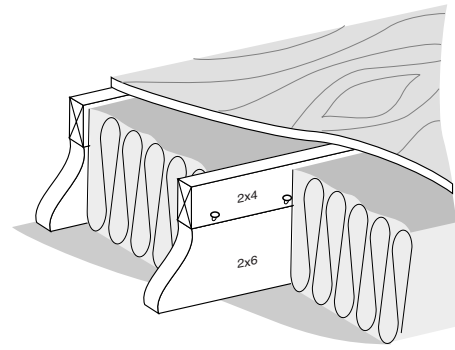

Increase Attic insulation levels under decking

A 2x6 joist provides enough depth for an R-19 to R-21 insulation value. Each inch of additional depth permits R-3 to R-4 (using typical fiberglass batts), so adding a 2x4 extension would provide the 10 inches needed for a standard R-30 batt.

Construct an Attic Stairs Cover Box

Use the template shown here to cut pieces from a single 4'x8' sheet of 1/2-inch rigid insulation. Be sure to carefully measure both inside and outside dimensions to the appropriate length, width, and depth clearances for the cover box.

Create the box as shown: Apply adhesive/mastic and use roofing nails to construct the two end and two side pieces. Assemble the side and end pieces into a box using adhesive and longer nails. Add the center support brace and cover piece with glue and nails. A faced insulation batt can be glued to the cover piece with adhesive applied to the paper backing.

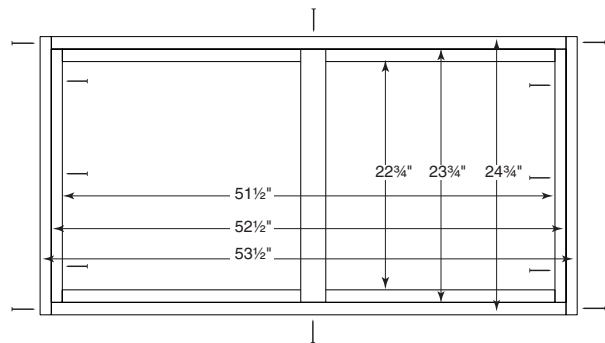

Assemble side pieces, end pieces, and brace as shown. The cover piece will drop in and be attached with adhesive and nails.

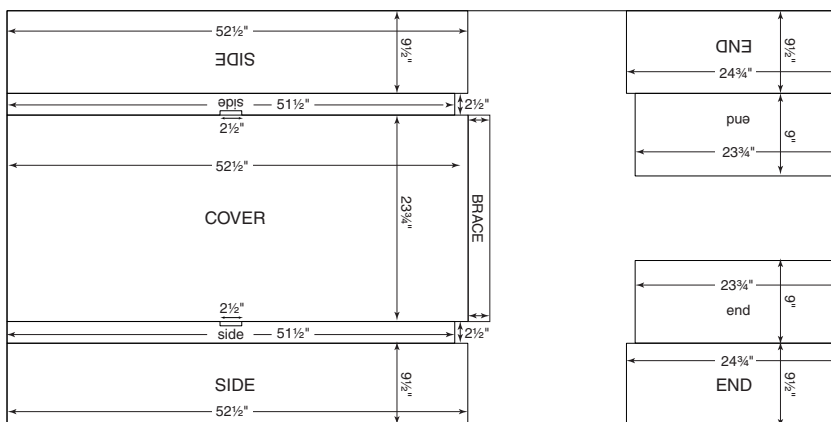

Dimensions shown are for a box 53 1/2" outside (51 1/2" inside), 24 3/4" outside (22 3/4" inside), and 9" of depth inside. Adjust dimensions to fit the specific stairs being installed.

Materials needed:

- Rigid Insulation such as 1/2-inch extruded polystyrene
- Fiberglass batt (optional)
- Duct sealing mastic or construction adhesive
- 1" roofing nails, 8d or 16d nails
- Tape measure, sharp utility knife, and straight-edge; or table/circular saw
- Weatherstripping/gasket material with adhesive

Knee walls

Another type of attic access is a *knee-wall door*. A knee wall is typically a partial height wall that is usually found in the upstairs level of finished-attic homes. Knee walls are notoriously leaky and often poorly insulated as builders and homeowners forget that the other side of the wall is unconditioned attic space. Make sure that the knee-wall door is weatherstripped and has a latch that pulls it tightly against the frame and weatherstripping to achieve a solid seal. Use construction adhesive and screws to attach rigid insulation to the attic side of the door. Some attic doors are full-height interior doors; these should be insulated, weatherstripped, and equipped with a tight threshold.

Inspect the rest of the knee wall. If not enough insulation is installed (R-19 is the minimum recommended), consider covering the back of the vertical knee wall with rigid insulation. Insulated sheathing, with the seams caulked or sealed with housewrap tape, reduces heat flow and minimizes the comfort problems commonly associated with drafty attic knee walls.

Insulated rafters

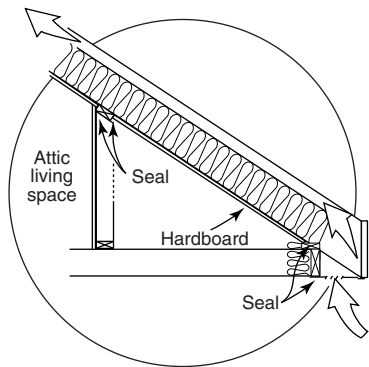

In new construction, an improved approach is to insulate and air seal the rafter space along the sloped ceiling of the knee wall. The rafters should be covered with a sealed air barrier, such as drywall, rigid insulation, or foil-faced hardboard. The advantage of this approach is that the storage area as well as all the ductwork is now inside a more tempered space.

Attic knee wall

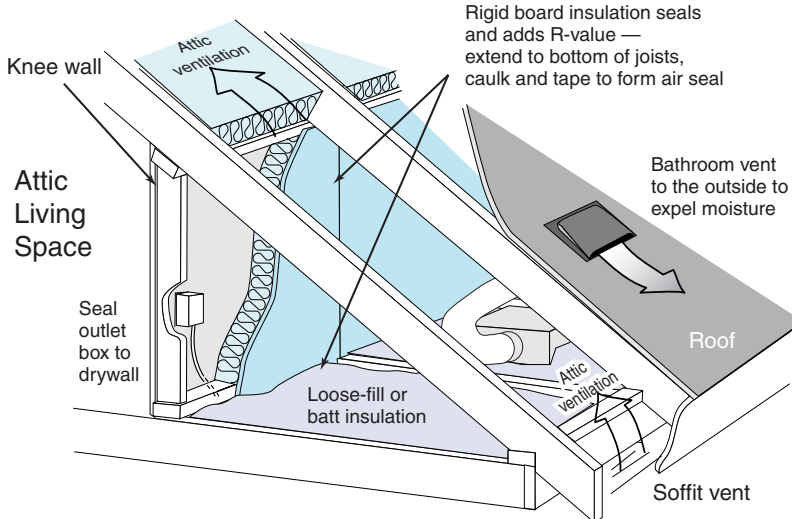

The attic knee wall is often underinsulated and leaky. Install adequate insulation and air seal around the living space for continuity in the building envelope.

Knee wall door

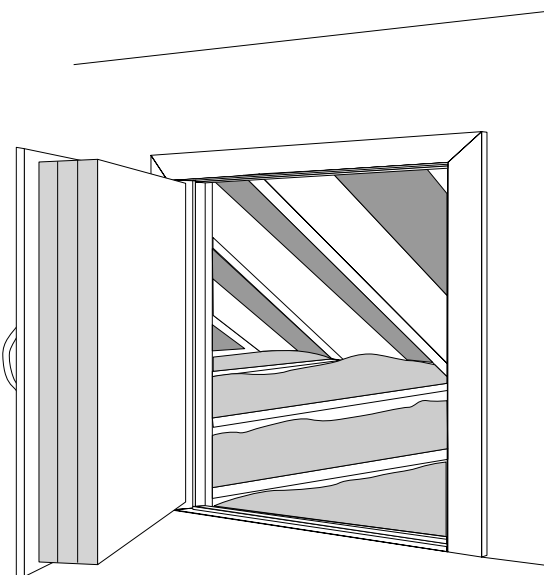

Add R-value to the knee-wall door, by adhering rigid insulation board (sandwiched together with construction adhesive and screws) to the back of the door. The clearance between the insulation and the door frame as well as air sealing details will require special attention.